

SOLAR CHARGE CONTROLLER SNC Series

User Manual

Thank you very much for buying our product ,Please read thoroughly before using the prouoct

Description of Functions

1. The charge controller automatically recognize 12V or 24V system.
2. Mainly suitable for small off-grid solar power system, for example: home solar power systems, ships, self-service base stations, outposts, etc.
3. LCD display various parameters of charge and discharge.
4. Boost charge voltage and battery low voltage protection point can be adjustable
5. The three-stage PWM charging mode
6. Load output can be manually controlled.
7. With high-precision temperature compensation function.
8. With electronic protection

Attentions

The charge regulator is intended for use in photovoltaic systems with 12V or 24V nominal voltages, It shall be used with vented or sealed (VRLA) lead acid batteries only.

Safety Recommendations:

1. Batteries store a large amount of energy. Never short circuit a battery whatever.
2. Batteries can produce flammable gases. Avoid making sparks, using fire or any naked flame. Make sure that the battery room is ventilated.
3. Avoid touching or short circuiting wires and terminals. Be aware that the voltages on specific terminals and wires can be up to double of battery voltage. Use isolated tools. Stand on dry ground and keep your hands dry.

Installation

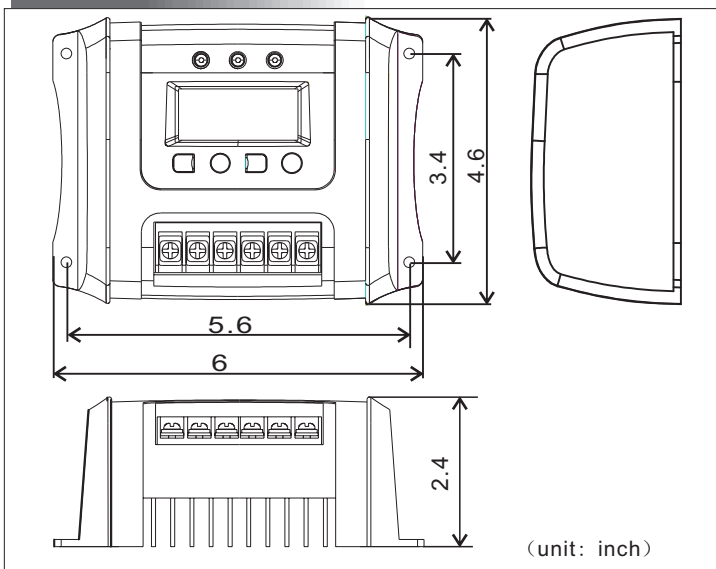

Please installed in the room, avoiding direct-clearance, do not install in the wet environment, when use it outdoor, please install controller and batteries in the same place, and the batteries installed in the same place, the controller can measuring the battery temperature, charge voltage regulation.

Attention:

1. Screws specifications M3 × 10
2. Make sure heat-location were not I blocke

Connecting

接线方法

1. Connect sequence 1. battery --2. solar array --3.loads
2. Wire size: 10A: Min2.5mm²
15A/20A: Min4mm²
30A/40A: Min4mm²
3. Grounding the solar system: Be aware that the positive terminals of the SNC controller are connected internally and therefore have the same electrical potential. if any grounding is required ,always do this on the positive wires.

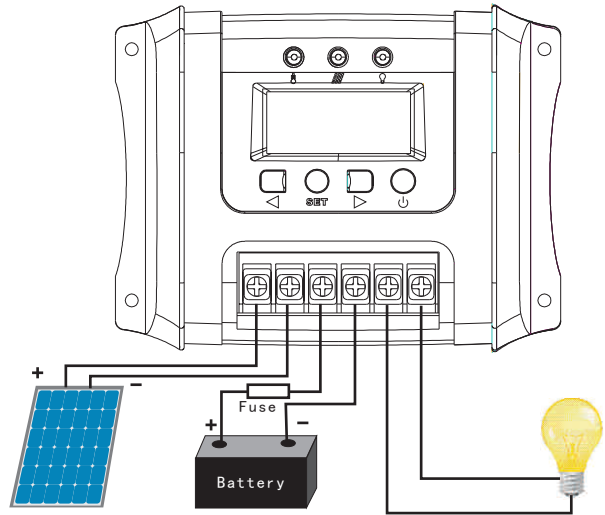

Part Names

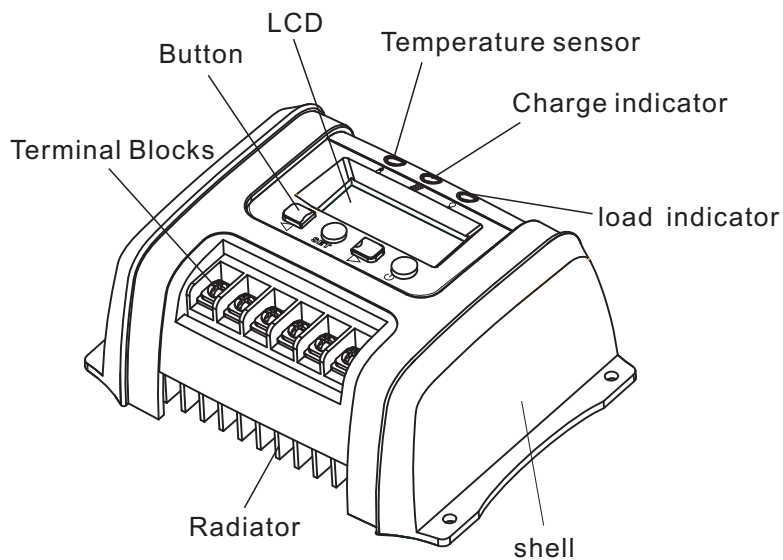

charge indicator (green LED)
ON: charging
OFF: no charging

charge indicator (Red LED)
ON: Stop output
OFF: Output normal

Operating

Parameter Browse

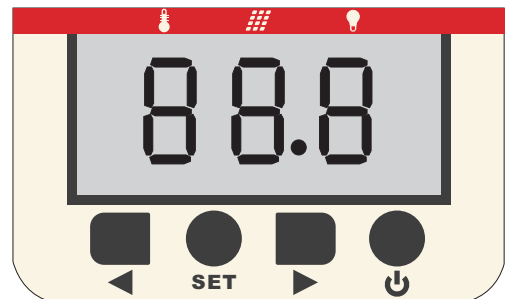
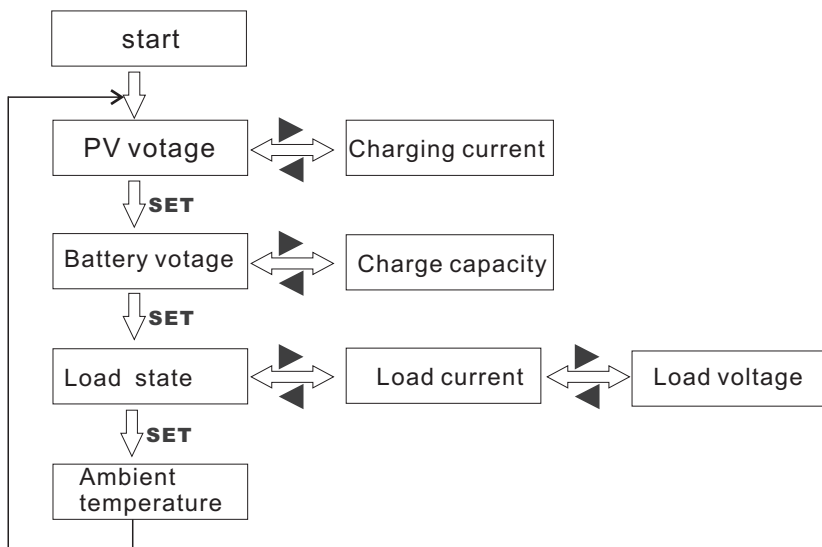

Key Description

	Previous
	Function key, cycle display main menu
	Back
	Load ON/OFF

setting

The controller user can modify:

1. Boost voltage
2. Load low-voltage protection point
3. Temperature units.
4. Charging capacity cleared

When you are make setting operation, the related number will twinkle. After you finish the setting, the twinkle will stop and the related number will save.

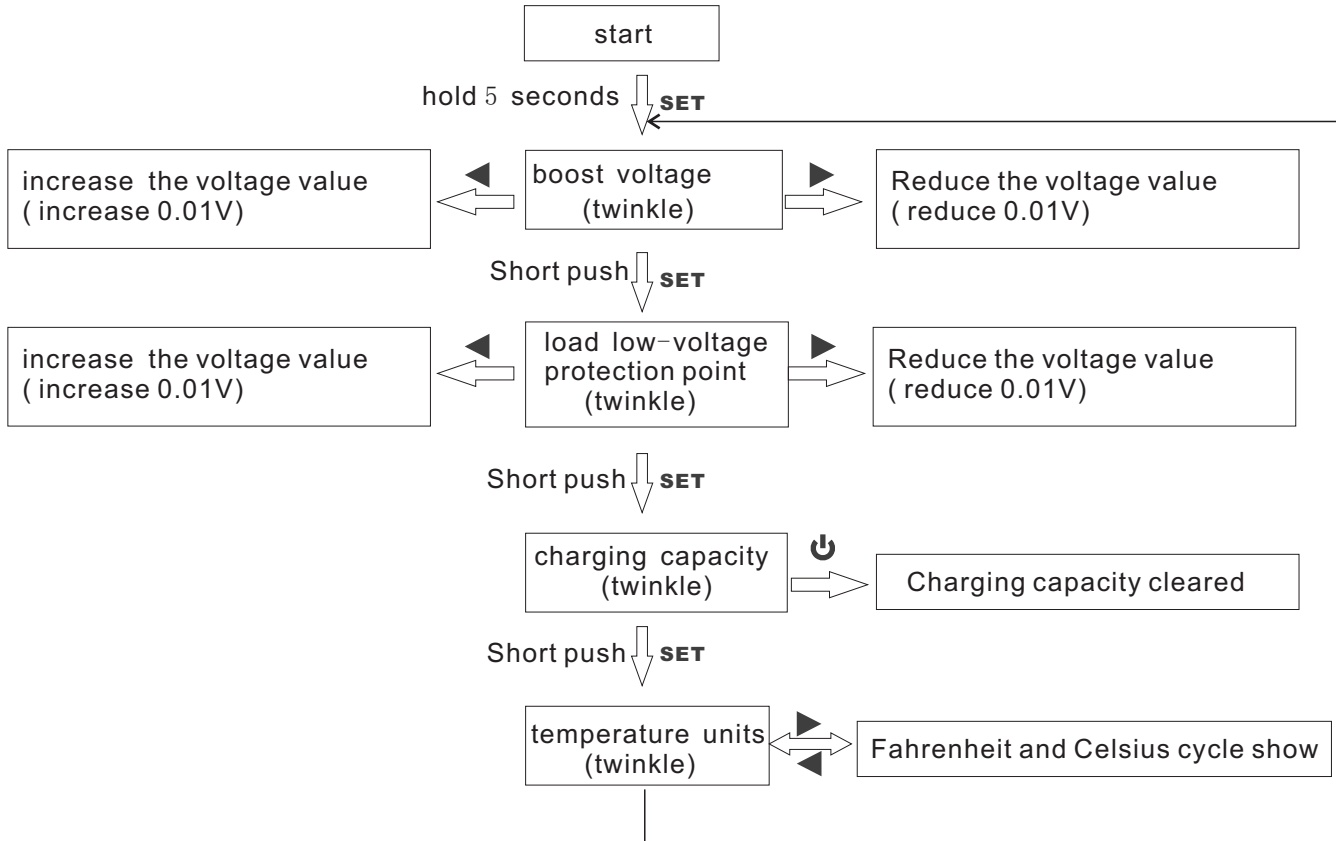
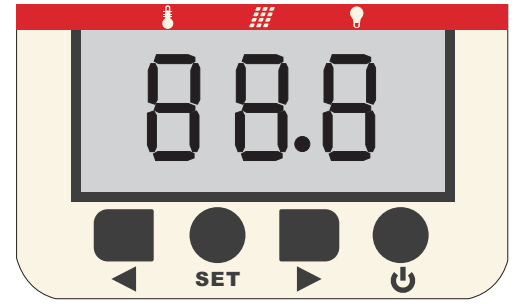

Technical Date

MODEL	SNC10	SNC15	SNC20	SNC30	SNC40
Max. solar panel current	10A	15A	20A	30A	40A
Max. load current	10A	15A	20A	30A	40A
Use voltage	12V/24V, automatic recognition				
NO-load current	10 mA				
Overvoltage protection	15.5V(12V), 31V/24V;				
Work temperature range:	-35°C--+55°C				
Boost voltage	14.6V(12V), 29.2V/(24V)				
Equalization voltage	14.8V(12V), 29.6/(24V)				
Float voltage	13.8V(12V), 27.6V/(24V)				
Recharge voltage	13.2V(12V); 26.4/(24V);				
Temperature compensation	-5mv/°C/2V				
Low-voltage disconnect	11V(12V); 22/24V;				
Load reconnect voltage	12.6V(12V), 25.2/(24V) ;				
Charge control mode	PWM				
diplay mode	LCD				